

## 11. Spar Box Install & Wing Alignment



Date Completed:

**Section Overview:** The proper installation of the spar box. To correctly align the wings and install the attachment hardware.

**Required Parts:** Spar Box front #ALS-0010, spar box rear #ALS-0011, Angle of Incidence plates #ALW-0011

**Required Hardware:** 4 AN5-7A, 8 AN5-10A, 45 AN970-5 wide area washers, 14 AN365-524 nyloc nuts 5 AN3-5A bolts, 5 AN365-1032 nyloc nuts, 4 1.5" long #8 counter sunk screws, 4 AN365-832 nyloc nuts.

**Required Tools:** SAE socket set, SAE wrench set, 5/16" drill bit, 3/16" drill bit, 5/32" drill bit, counter sink bit, straight edges, rulers, tape measures, level, digital level, torque wrench.

**Required Conditions:** None

**Required Skills or Training:** Basic use of hand tools, and knowledge required to use them, ability to read and carry out directions, read and understand simple CAD drawings.

**NOTE: Section 1, #8 thru #13 must have been completed. Section 5 #1 thru #13 must have been completed before proceeding!!!**

1. This section will take time make sure not to have distractions.
2. The cord line must be well marked and the cut out completed earlier must be accurate and square to the cord line
3. Use the picture below as a reference, and the drawing on the next page for the correct measurements, left and right roots are identical.

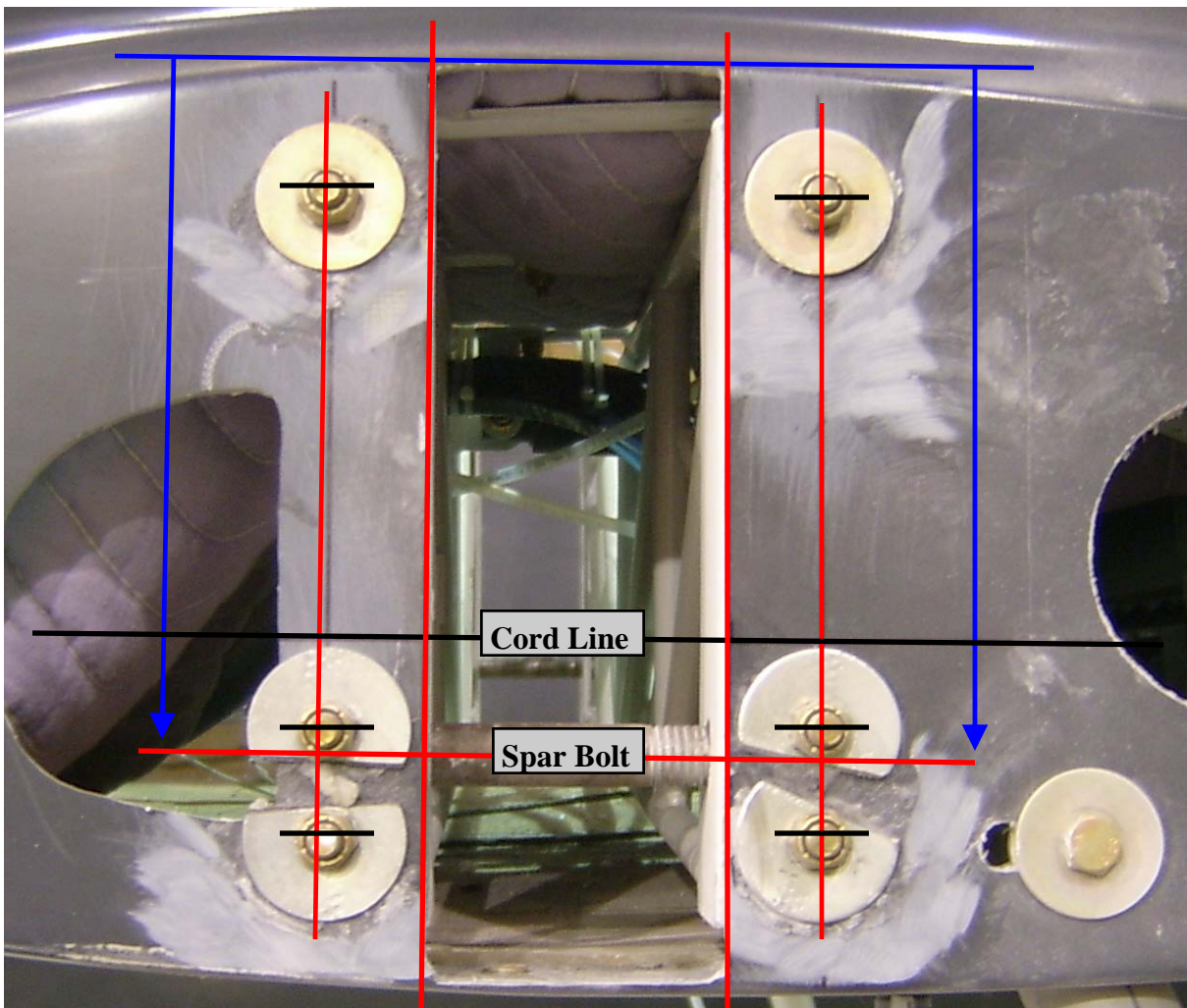

**Drawing legend**

**Black Box:** Cut out determined from Section 1, #8 thru #13.

**Blue Lines:** Upper and lower wing roots and or wing skins.

**Green Line:** Wing cord line.

**All Measurements approximate check individual box and wing measurements for accuracy.**

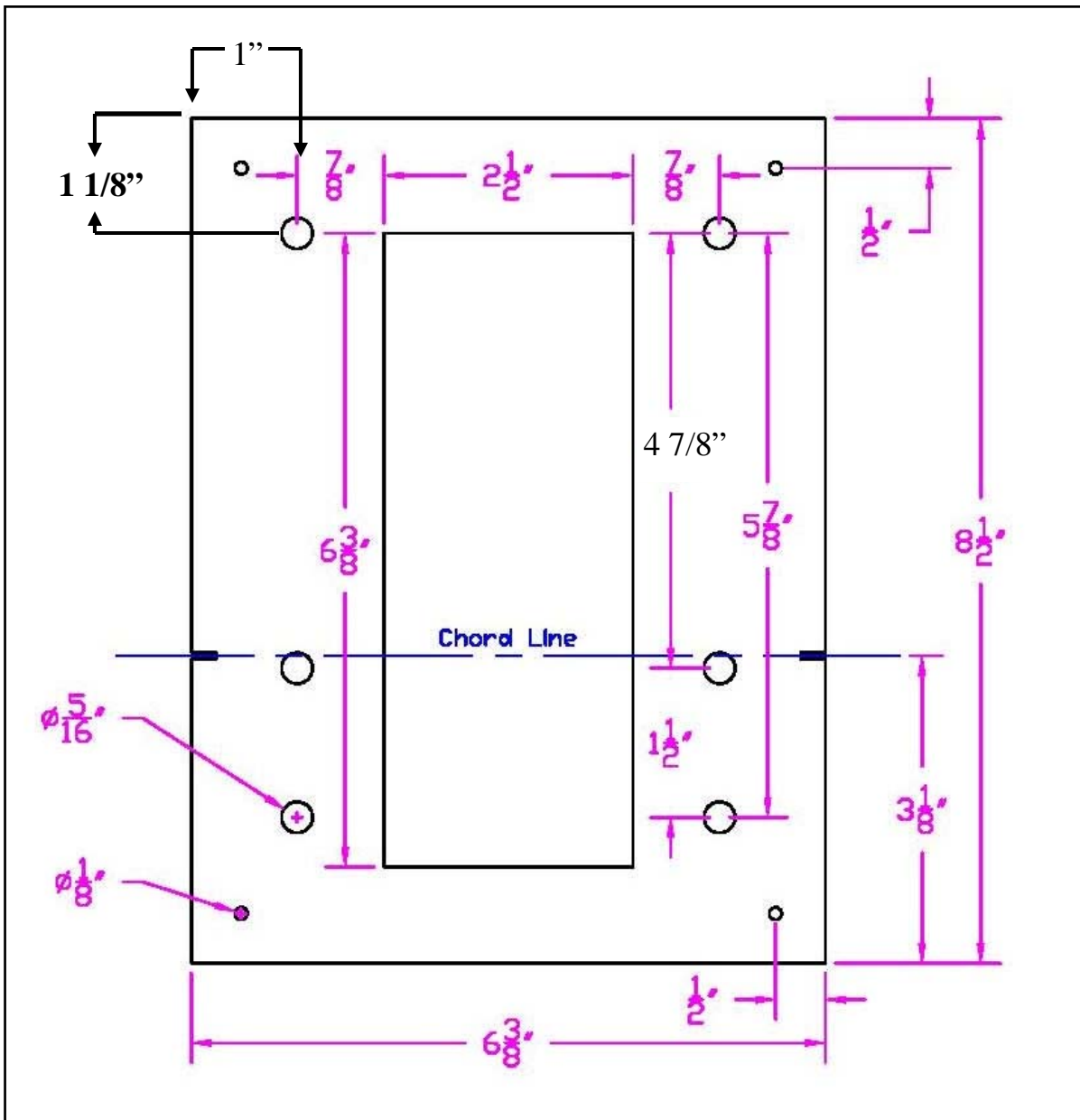

Date  
Completed:

## 11. Spar Box Install & Wing Alignment

4. With the wing root correctly marked and satisfied that the measurements have been double checked, drill all holes to 5/16”.
5. Install the front and rear spar box half for the final time.
6. The Upper bolts in the box will be AN5-7As and the bottom 4 bolts will be AN5-10As.
7. The bolts must go from the inside out with large area washers on the outside against the fiberglass.
8. The box is smaller than the fuselage so it will fit, so you must evenly take up the space between the box and the inside of the fuselage with large area washers.
9. Tighten the AN5 bolts down, this is the spar box, however you do not need to “crank’em” down, Follow standard torque specs for 5/16 bolts.

10. **Note:** It may be needed to file down the co-pilots side of the center tang on the top of the rear spar box. When fitting the halves together it may interfere with the flap motor tang that hangs off of the center tang on the front box.
11. Drill thru the pre-drilled holes in the front tangs thru the back half tangs with a number 10 drill bit ( 3/16)
12. Install AN3-4A and nyloc nuts in the box.

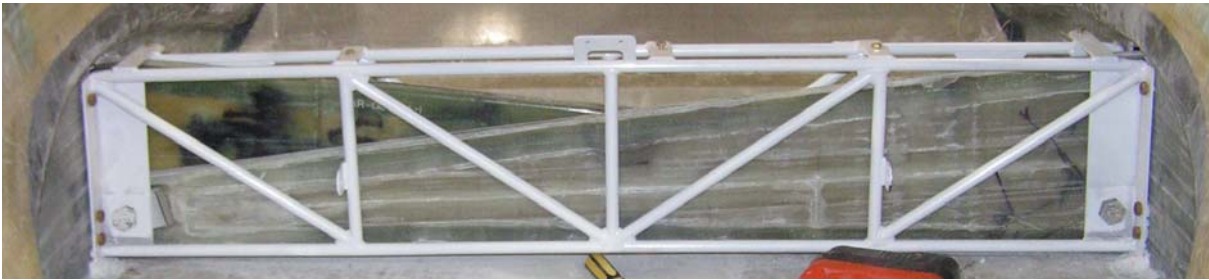

Date  
Completed:

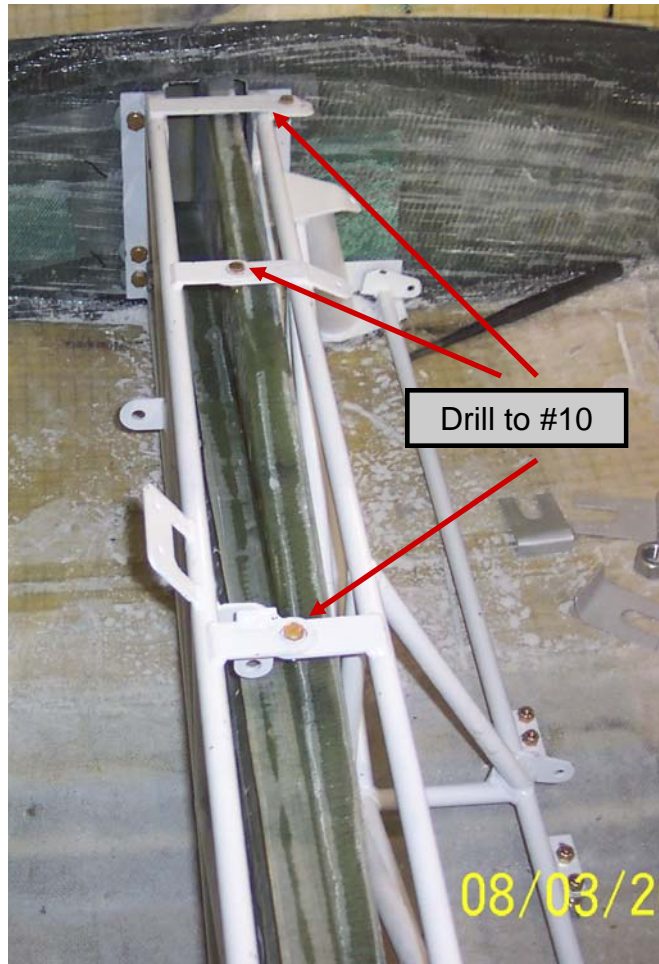
## 11. Spar Box Install & Wing Alignment



13. Install the wings into the spar box, the main spar bolts may simply slide thru and do not have to have nuts installed nor the main box shims at this point.



14. Starting with the **Left Wing**, position the wing fore or aft to have the leading edge of the wing to match the leading edge of the wing root.

15. Use some shims if needed to prevent the wing from moving while setting the angle.

16. Match the wing with the wing root on the fuselage, The critical points are the first 6-8" of the leading edge and the last 6-8" of the trailing edge, the center portion of the



wing is skin only and has no core material, this may be somewhat light and not a good reference for setting the wing.

17. Position the leading edge to match, back drill thru the 5/16" angle of incidence hole, insert a long 5/16" bolt to maintain the alignment.

18. Complete this same task for the Aft AOI hole.

19. When finished repeat this task for the right wing.

20. When aligning solely by the wing root on the fuselage we have found that the wing can be an exact match when taking your time, however some have been out 1-2 tenths of a degree with no noticeable effect on flight performance.

21. We do have a jig for AOI and can send a picture of that if you wish to build one your self.



Date  
Completed:

# 11. Spar Box Install & Wing Alignment



- 22. Remove the wings
- 23. Locate the Angle of Incidence plates in the kit. Part number, ALW-0011.

- 24. The plates will get mounted to the inside of the forward and rear hard points. That

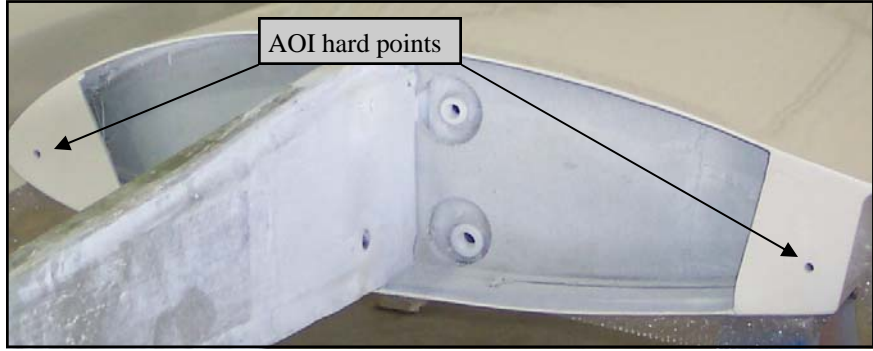

were matched drilled to the fuselage earlier.

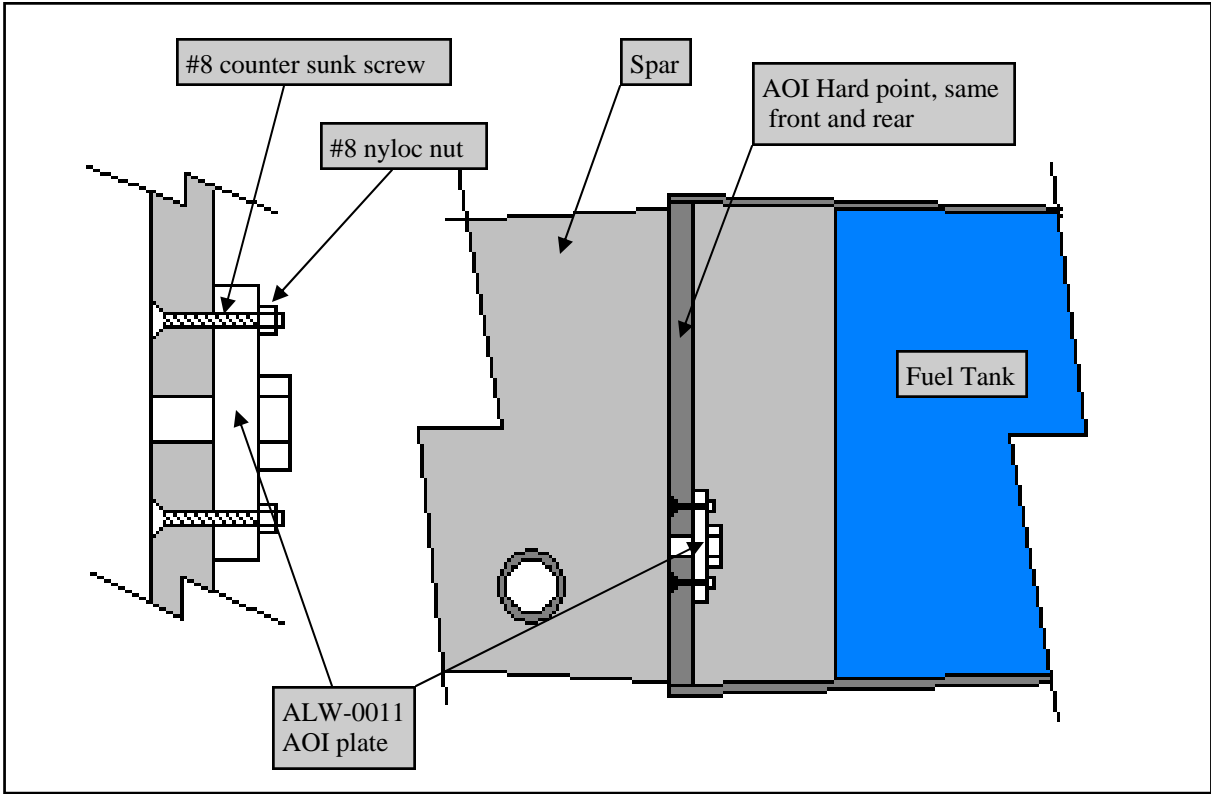

- 25. Hold the plate on the outside of the hard point first with the hole lined up.

- 26. Trace the size of the plate onto the out side of the hard point.

- 27. Insert a AN5-7a into the hole, screw the AOI plate on to the bolt on the back side or inside of the hard point.

- 28. Drill two 5/32" holes thru the hard point and the plate. These holes must be inside the circle you drew to make sure they capture the plate and should be on opposite sides of the plate.

- 29. Counter sink the holes you have drilled to mount the AOI plate. They must be deep enough that the screw are completely flush and maybe even slightly inset.

- 30. Install the plate with #8 counter sunk screws and nyloc nuts..

- 31. The screws are only to hold the plate in place and are not structural, you can choose to use 5/32" stainless steel counter sunk rivets of proper length.